

**STEREO TURNTABLE SYSTEM**

# **PS-X50**



## **Owner's instruction manual**

Before operating your new Sony turntable, please read this manual completely to become familiar with all its features and capabilities.

Keep this manual handy for future reference.

## OWNER'S RECORD

The model and serial numbers are located at the rear. Record these numbers in the spaces provided below. Refer to them whenever you call upon your Sony dealer regarding this product.

Model No. PS-X50

Serial No. \_\_\_\_\_

## WARNING

- To prevent fire or shock hazard, do not expose the unit to rain or moisture.
- To avoid electrical shock, do not open the cabinet. Refer servicing to qualified personnel only.

## TABLE OF CONTENTS

Precautions . . . . .	2
Notes on installation . . . . .	3
Parts identification . . . . .	4
Turntable assembly . . . . .	5
Cartridge installation . . . . .	5
Tonearm assembly and adjustment. . . . .	6
Connections . . . . .	8
Record playing . . . . .	8
Tips on record handling . . . . .	9
Maintenance . . . . .	10
Repacking for shipment . . . . .	10
Specifications . . . . .	10
Trouble checks . . . . .	11

## FEATURES

- The X'tal lock system maintains the turntable at an accurate nominal speed under voltage or temperature variations or aging, and shows excellent initial drift and load/speed characteristics.
- Direct drive system with the Sony's unique linear BSL (brushless and slotless) motor, resulting in extremely smooth torque and start-up characteristics.
- High precision speed monitoring system, utilizing 5-pole magnetic pick-up head and pulse coated platter rim for electronic speed sensing.
- The J-shaped tonearm using a long span trunnion perform sensitively and is adjustable in height to adapt any cartridge. The supplied lightweight aluminum alloy headshell is connected firmly to the shell from plug from four directions by the newly developed locking collar.
- Control switches located on front of base, permit dust cover to remain closed during operation.
- The cabinet made from a special inorganic (non-plastic) molded compound with low "Q" and newly developed resilient feet effectively minimize outside vibrations and eliminate acoustic feedback.

## PRECAUTIONS

- Check that the operating voltage for your unit is identical with that of your local power supply.
- Should any liquid or solid object fall into the cabinet, unplug the unit and have it checked by qualified personnel before operating it any further.
- Unplug the unit from the wall outlet if it is not to be used for an extended period of time. To disconnect the cord, pull it out by grasping the plug. Never pull it out by the cord.

## NOTES ON INSTALLATION

- Place the turntable on a level surface.
- Avoid placing the unit near electrical appliances (such as a television, hair dryer, or fluorescent lamp) which may cause hum or noise.
- Avoid any vibration such as from speakers, slamming of doors, etc.
- Keep the unit away from direct sunlight, extremes of temperature, or excessive dust and moisture.
- Allow 10 cm (4 inches) clearance behind the unit so that the cover can be opened.

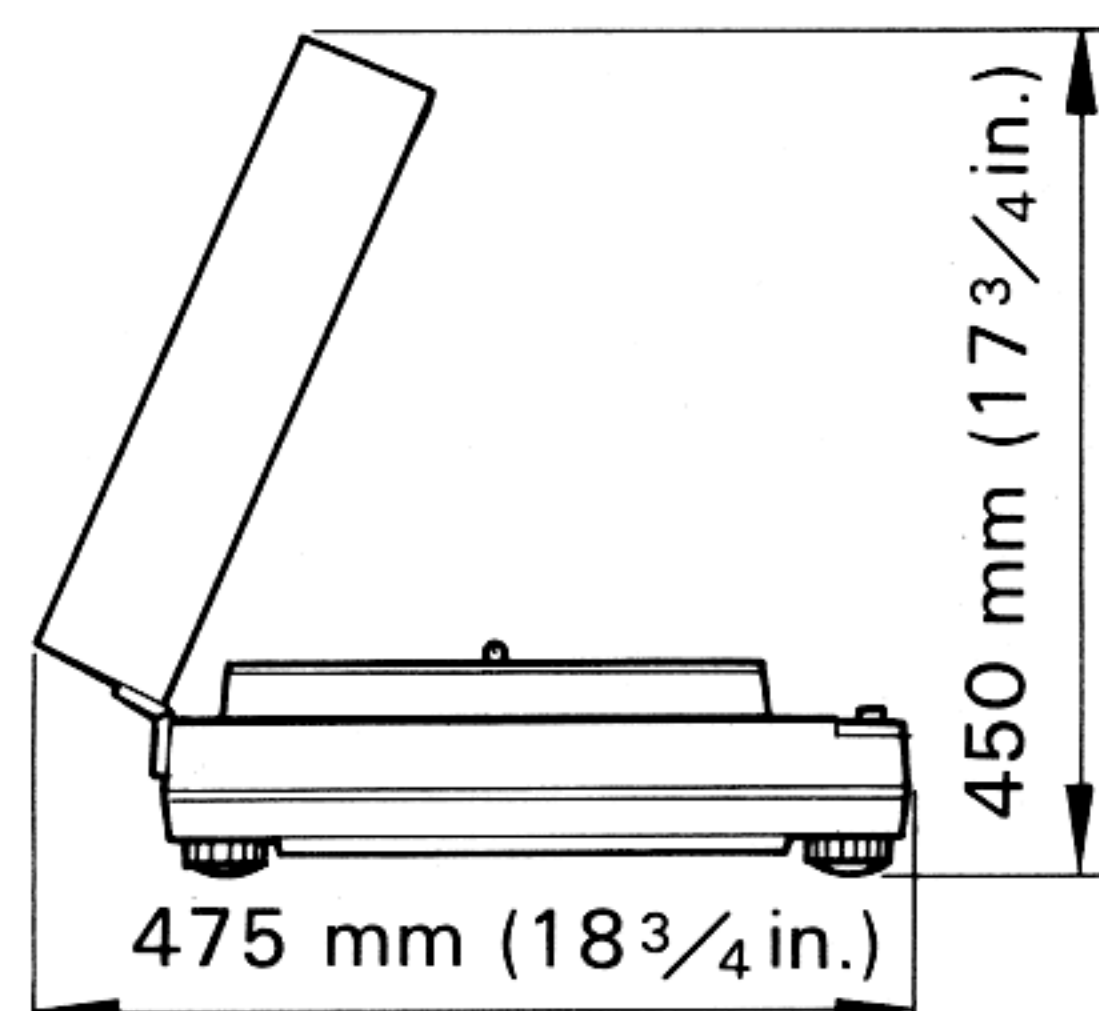

- The turntable has resilient feet that isolate the mechanism from external shock and vibration. Use them in locked position, but when placing the turntable on an uneven surface, turn each-foot until the unit is level.

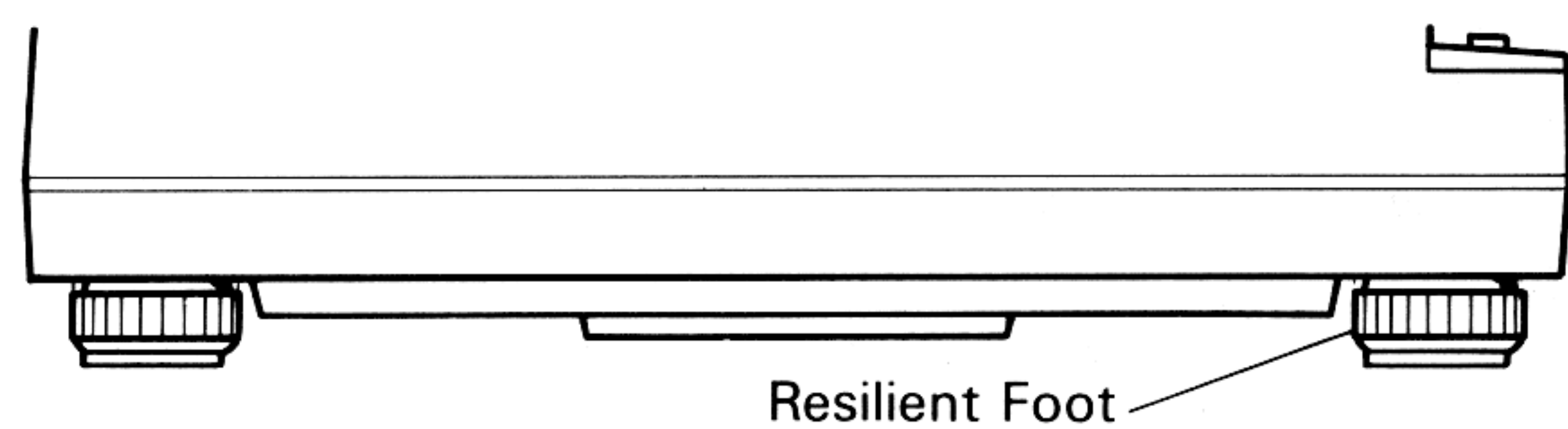

# PARTS IDENTIFICATION

The picture below shows the appearance of the assembled turntable.

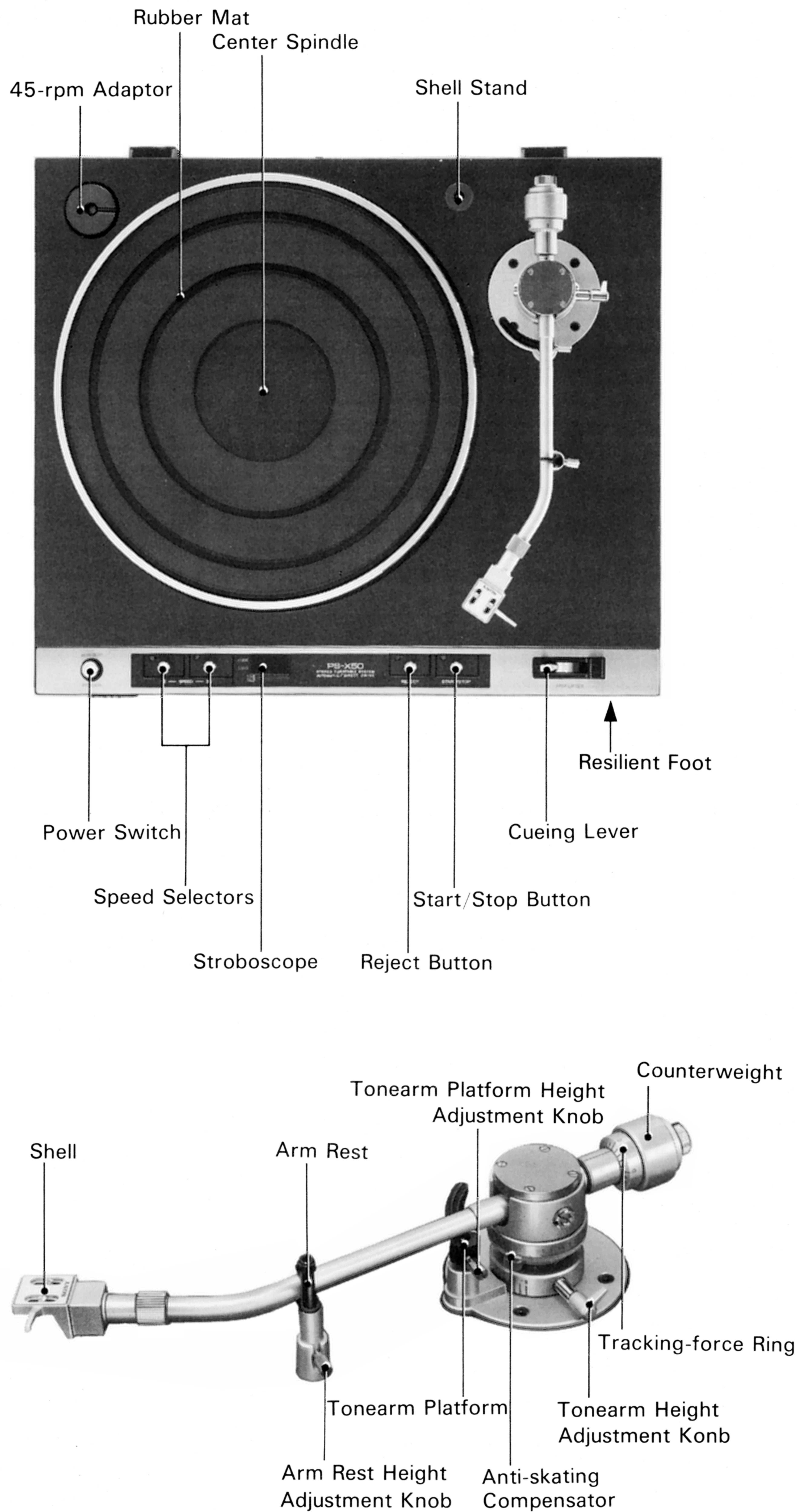

## TURNTABLE ASSEMBLY

Do not connect the power cord or the connecting cords until after finishing the assembly.  
Remove all packing material and clean the cabinet.

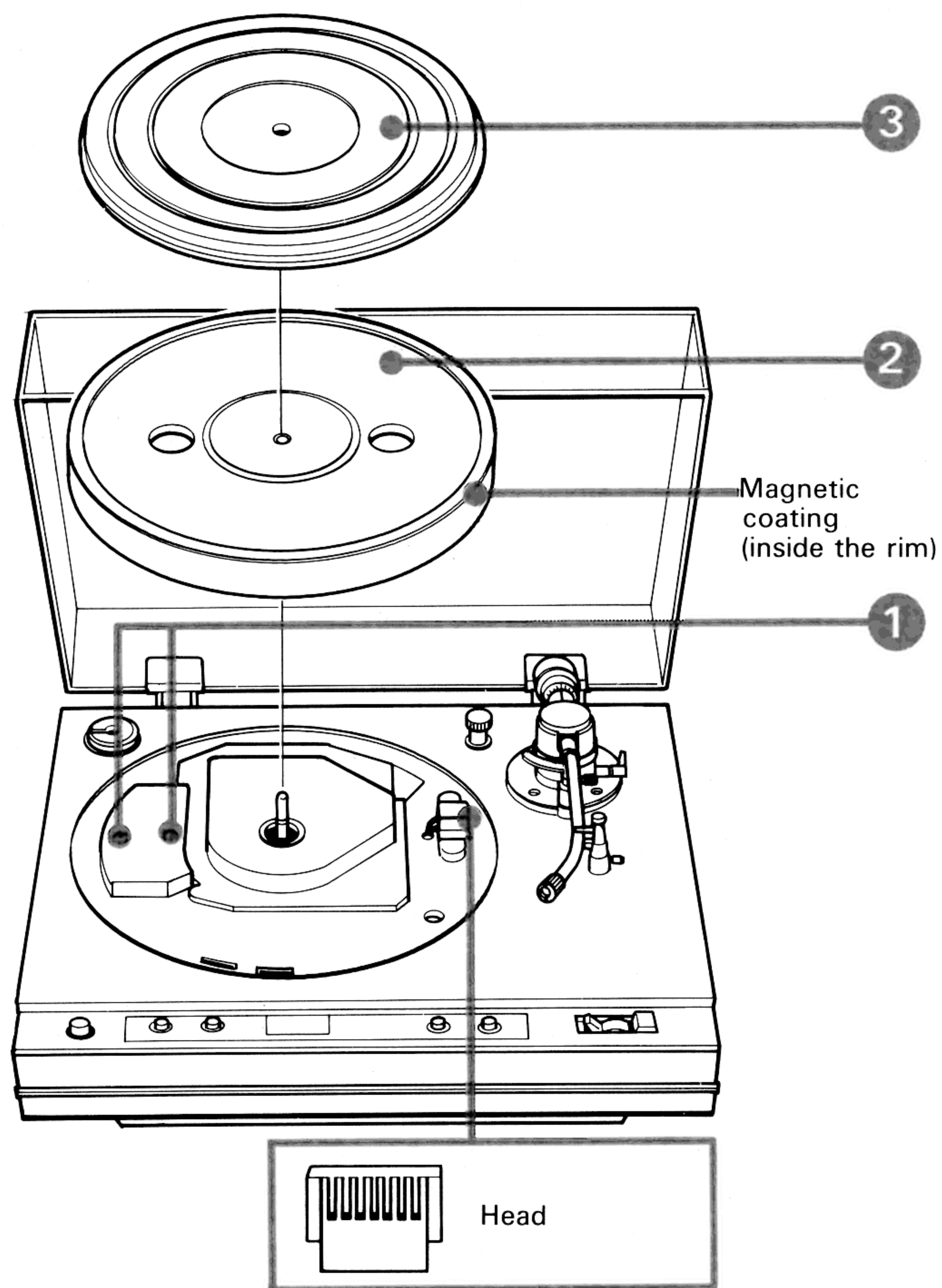

- ① Remove the red-painted transit screws. Save these screws, since they will be required when repacking.
- ② Carefully place the platter on the motor board by matching the center hole and the center spindle.
- Do not touch the magnetic coating with your fingers or damage the magnetic pick-up head.
- ③ Place the rubber mat on the platter.

### To remove the dust cover

Open the dust cover fully and slide it as illustrated while holding it with both hands.

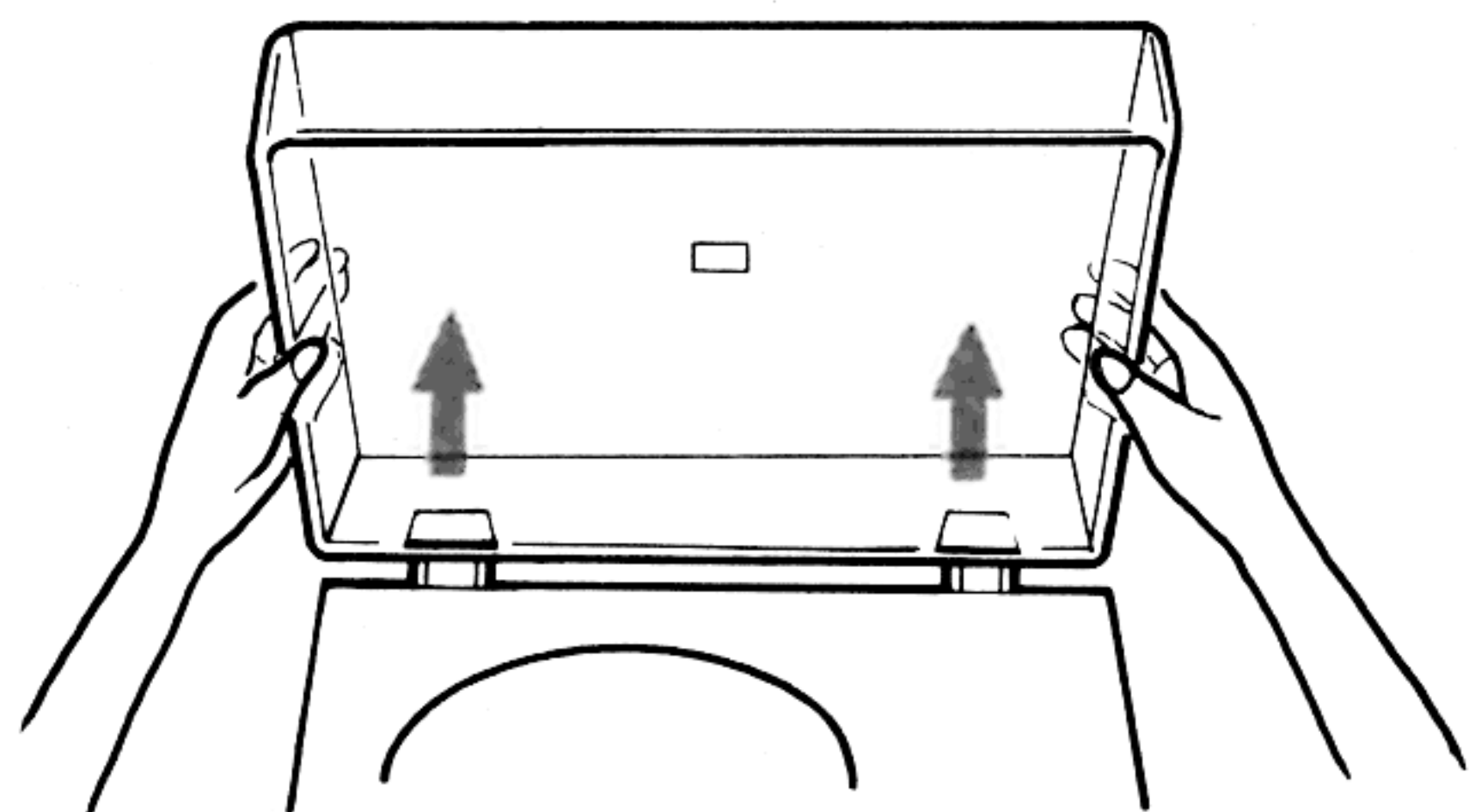

## CARTRIDGE INSTALLATION

A cartridge weighing up to 8.5 g can be mounted with the supplied shell.

Heavier cartridges from 8 to 16.5 g can be mounted using the extra weight (supplied).

① Install the cartridge into the shell with the mounting screws so that the distance between the shell end and the stylus tip is approx. 49 mm (1 15/16 inches). The temporary overhang adjustment is then complete. More precise adjustment should be made later.

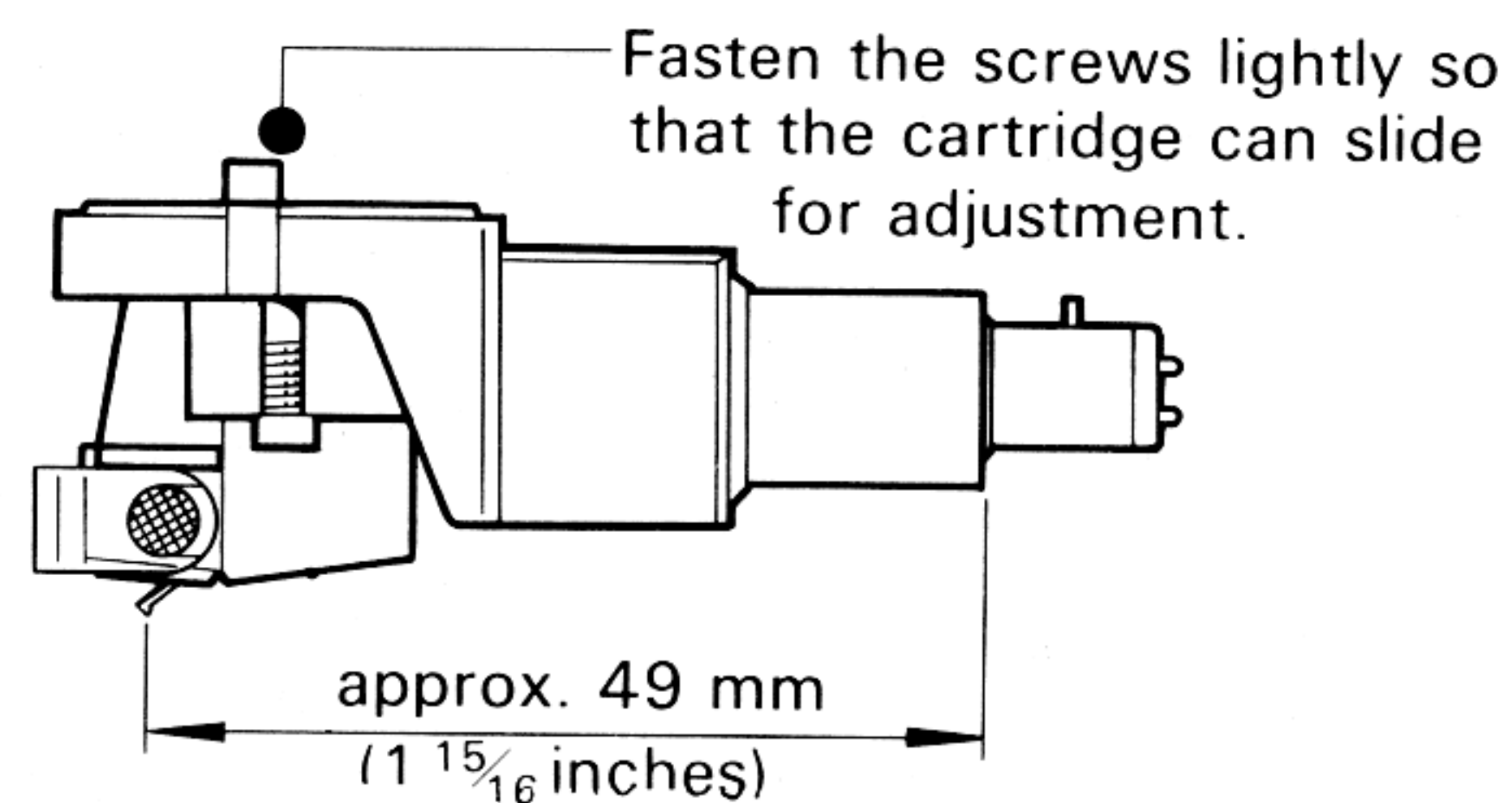

② Connect the lead wires of the shell to the corresponding pins on the cartridge.

Wires	Cartridge pins
White . . . . .	White, L (left channel signal)
Blue . . . . .	Blue, LE or G (left channel ground)
Red . . . . .	Red, R (right channel signal)
Green . . . . .	Green, RE or G (right channel ground)

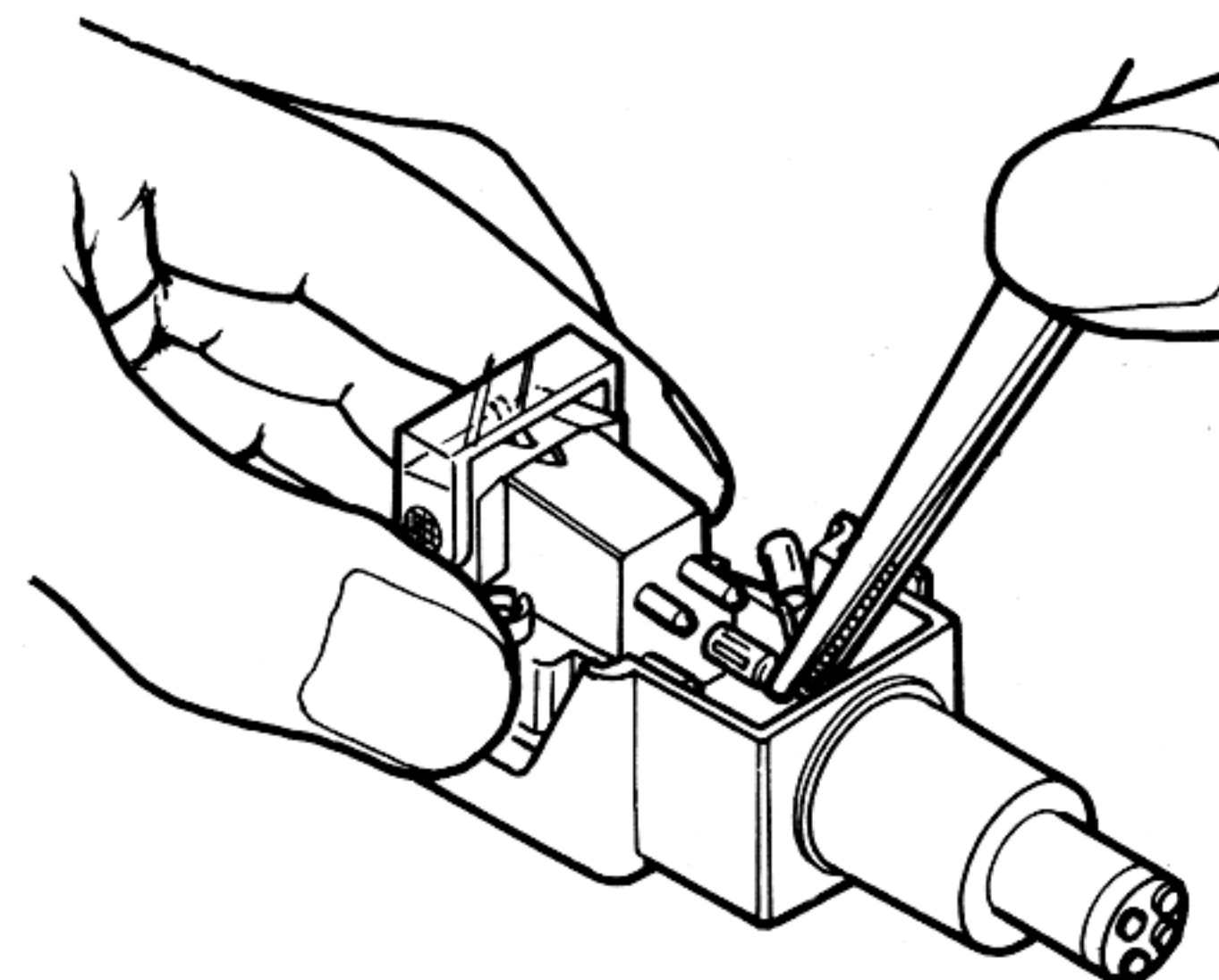

● A shell stand is provided on the base of the turntable for an extra mounted cartridge.

# TONARM ASSEMBLY AND ADJUSTMENT

Do not connect the power cord or the connecting cords until the assembly and adjustments are complete.

The following procedures should be performed on a level surface. Be careful not to damage the stylus tip while making adjustments.

When a cartridge is replaced, readjustments are required.

## Preparation

- ① Secure the Tonearm to the Arm Rest and set the Cueing Lever to [ ▼ ]
- ② Plug the Shell into the Tonearm and turn the Locking Collar counterclockwise until the Shell is firmly locked.
- ③ Insert and turn the Counterweight counterclockwise several turns.

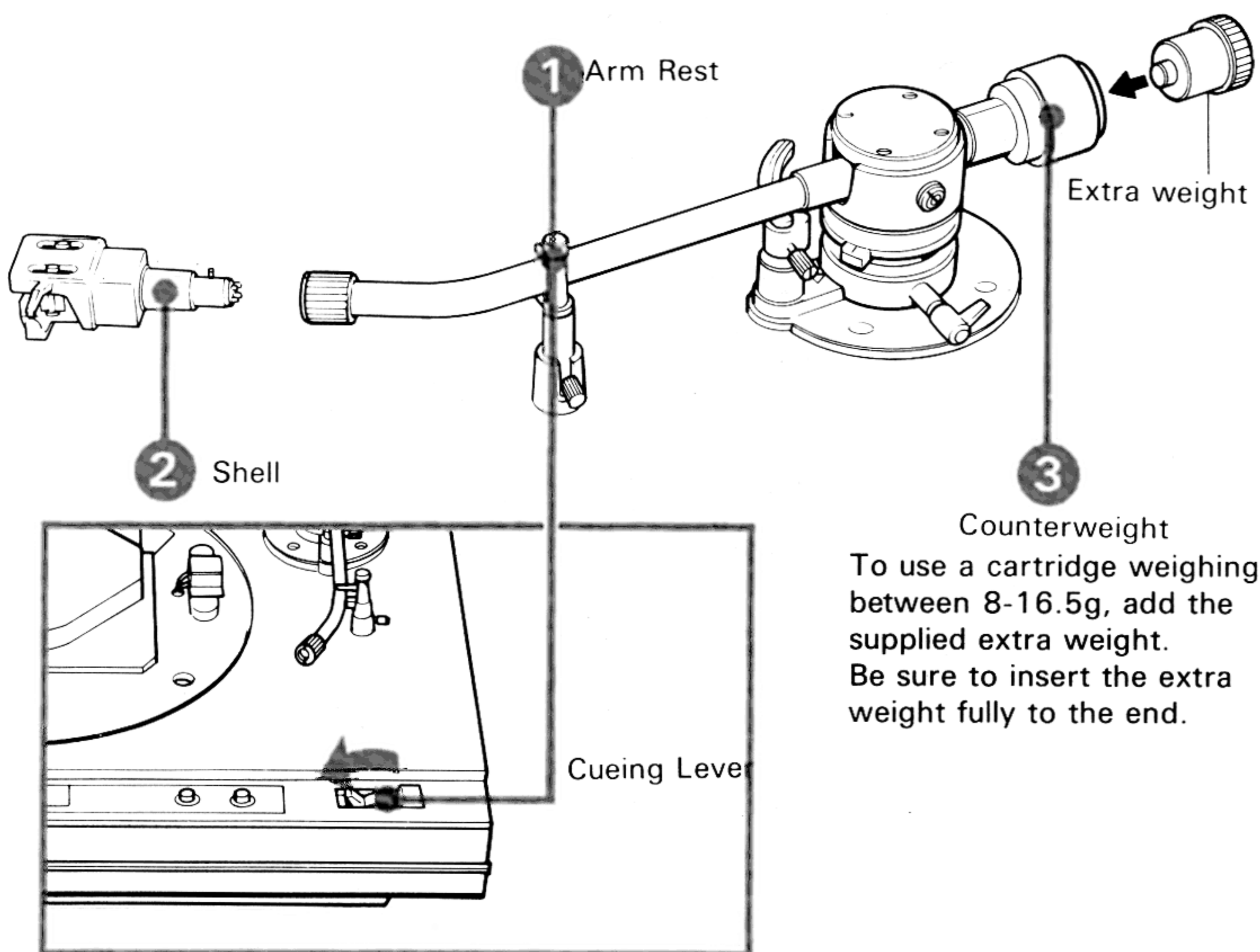

- ④ Remove the stylus guard, if fitted.

## Longitudinal balance adjustment \*1

- ① Be sure that the Anti-skating Compensator is set at "0". Release the Tonearm from the Arm Rest.

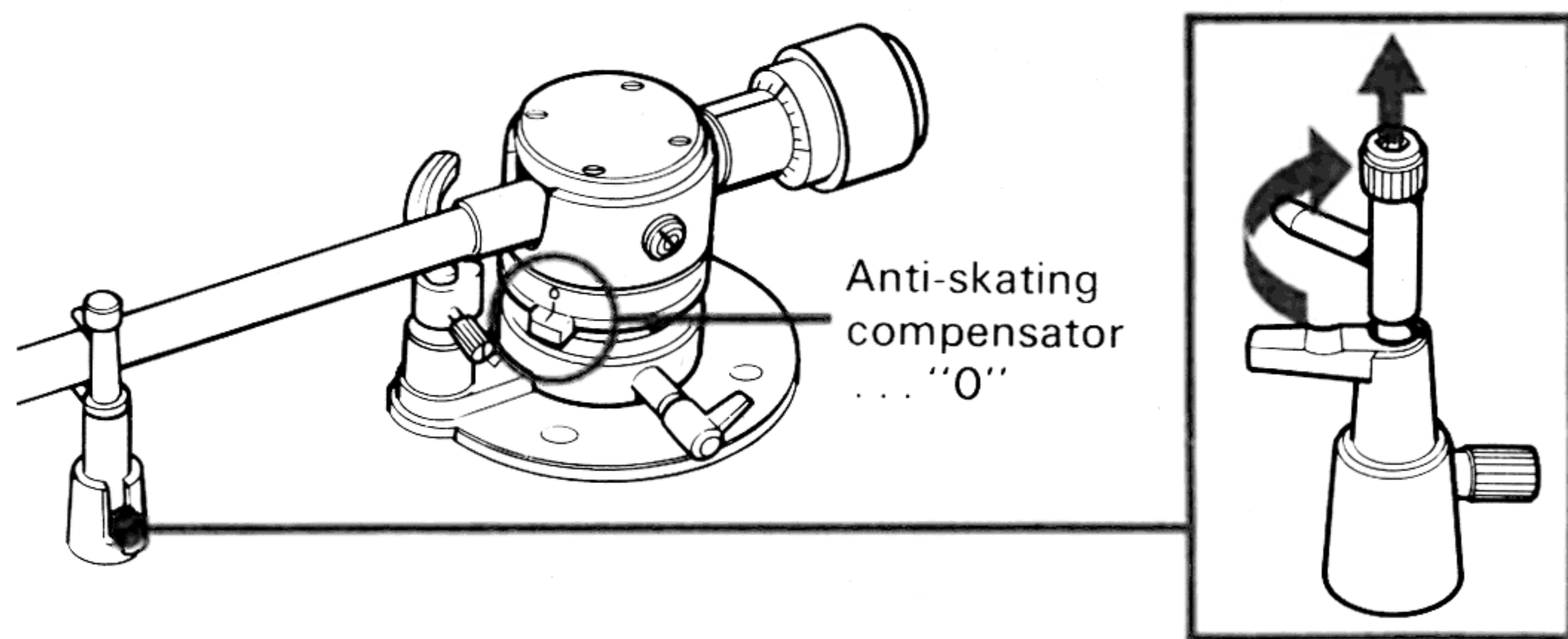

- ② Turn the Counterweight as required until the Tonearm is in a horizontally balanced position.

Release your fingers and check the balance. Repeat this step until the arm balances.

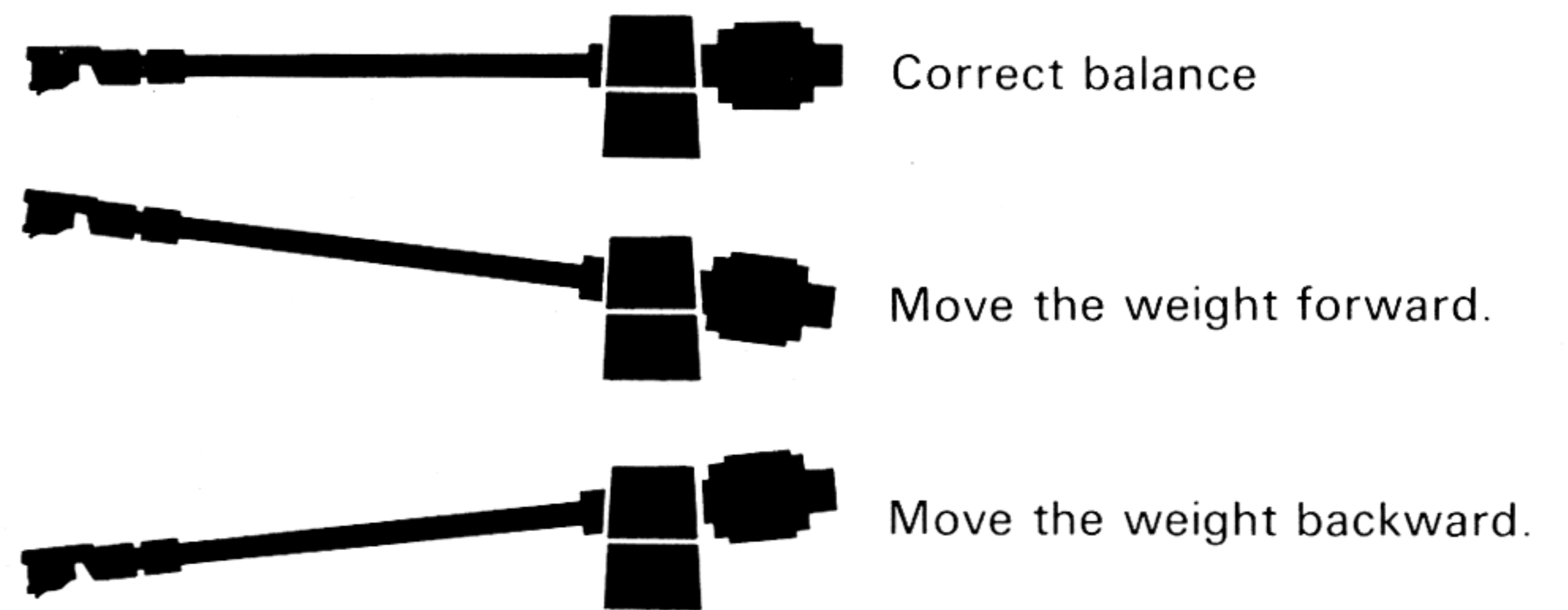
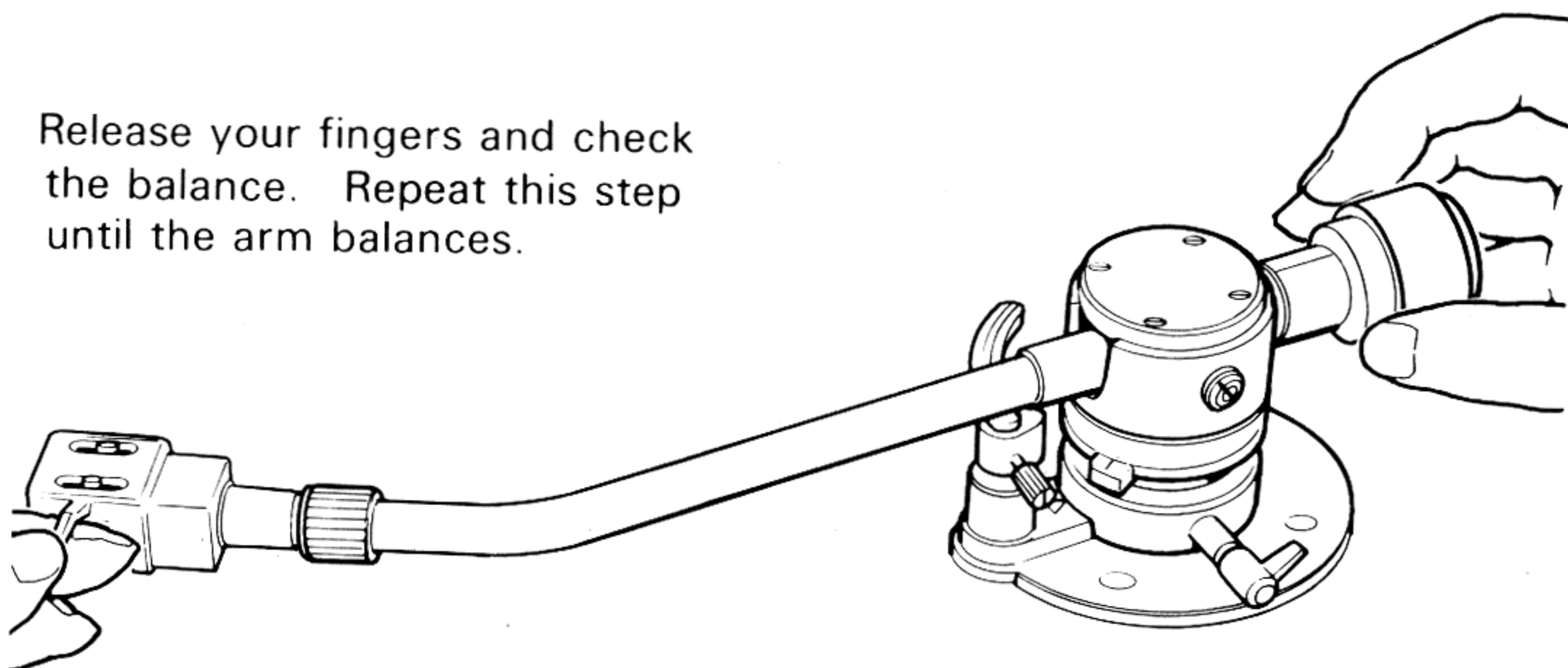

- ③ While holding the Counterweight at the balanced position, separately turn the Tracking-force Ring until the "0" indication meets the center line on the Tonearm. Recheck the balance.

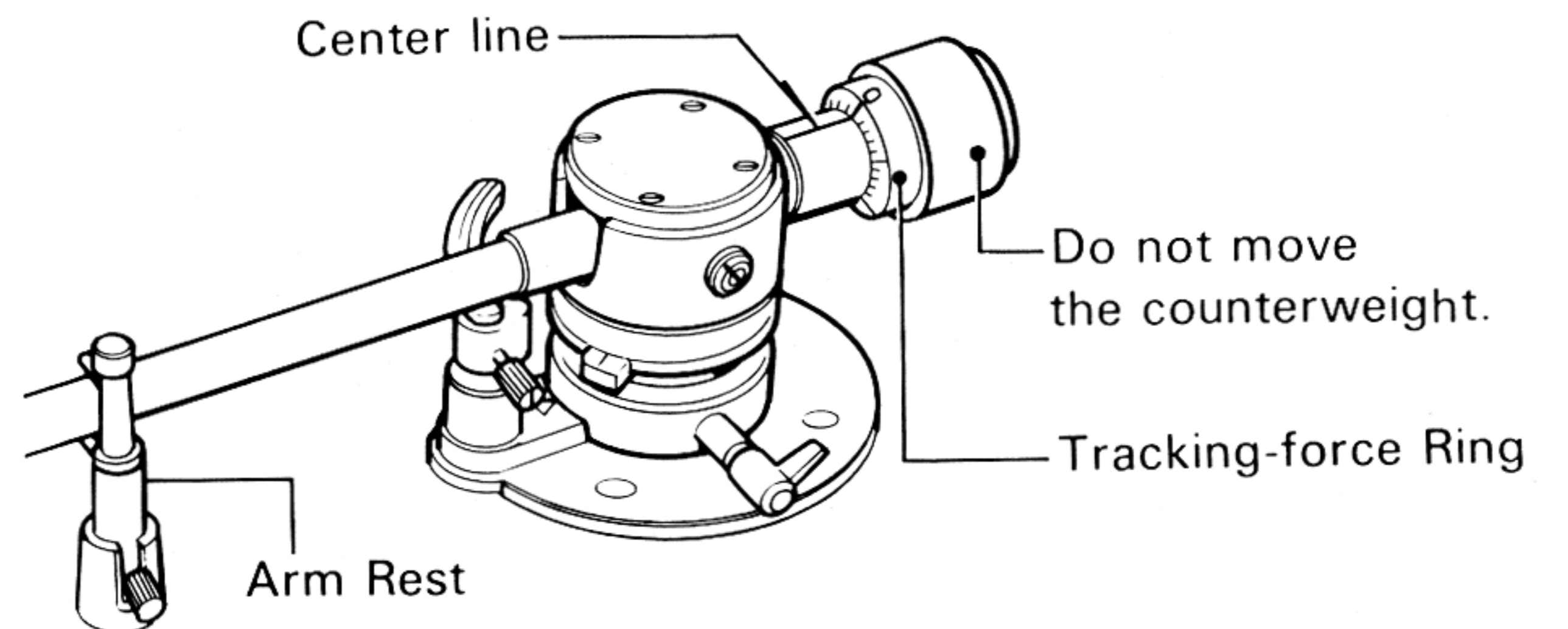

- ④ Secure the Tonearm to the Arm Rest again.

## Tracking-force adjustment \*2

Turn the Counterweight counterclockwise so that the recommended tracking-force figure for your cartridge is aligned with the center line on the Tonearm. The maximum tracking force available is 2.5 grams.

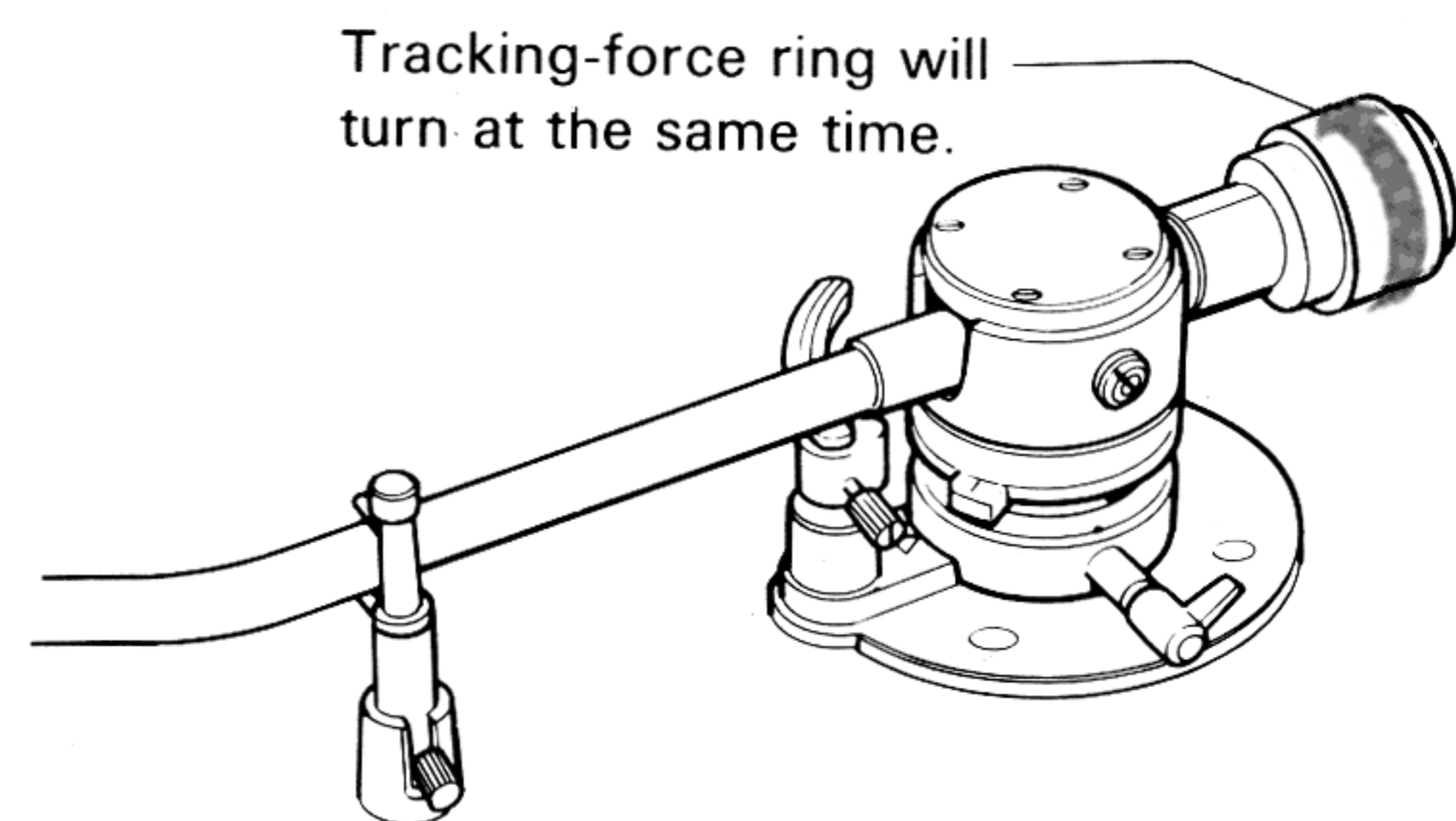

## Overhang check \*3

Check that the stylus overhang is set correctly by using the "235" Alignment Protractor on the back of the rubber mat.

- ① Place the rubber mat upside down.
- ② Bring the Tonearm above the cross point of the two fine lines, and carefully lower the stylus on the cross point with the Cueing Lever.
- ③ Check to see that the Shell is parallel to the lines drawn on the rubber mat as shown in the center illustration. If they are parallel, the stylus overhang is set correctly.

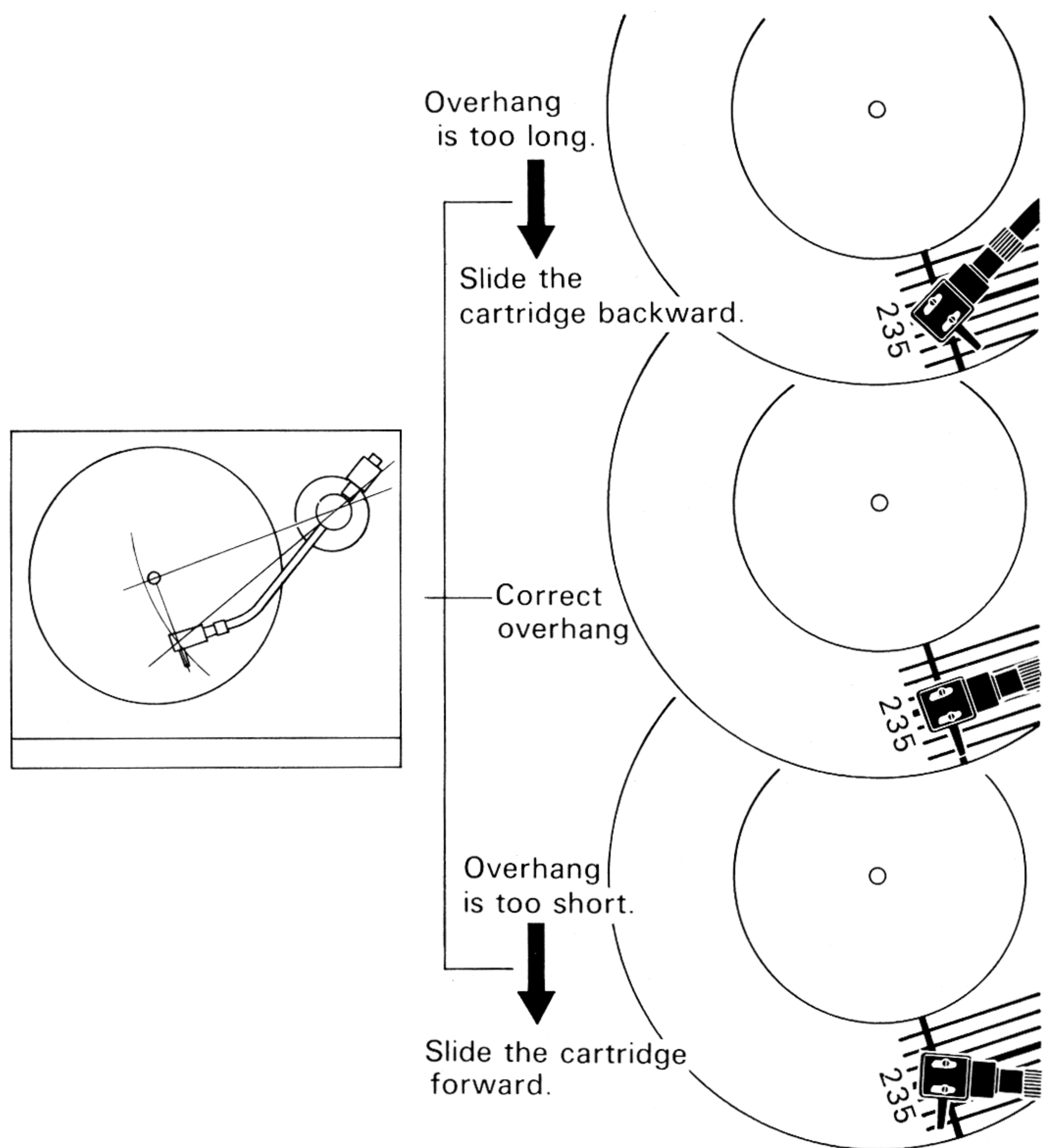

#### Anti-skating compensation \*4

Turn the Anti-skating Compensator so that the guide mark is aligned with the tracking-force value used.

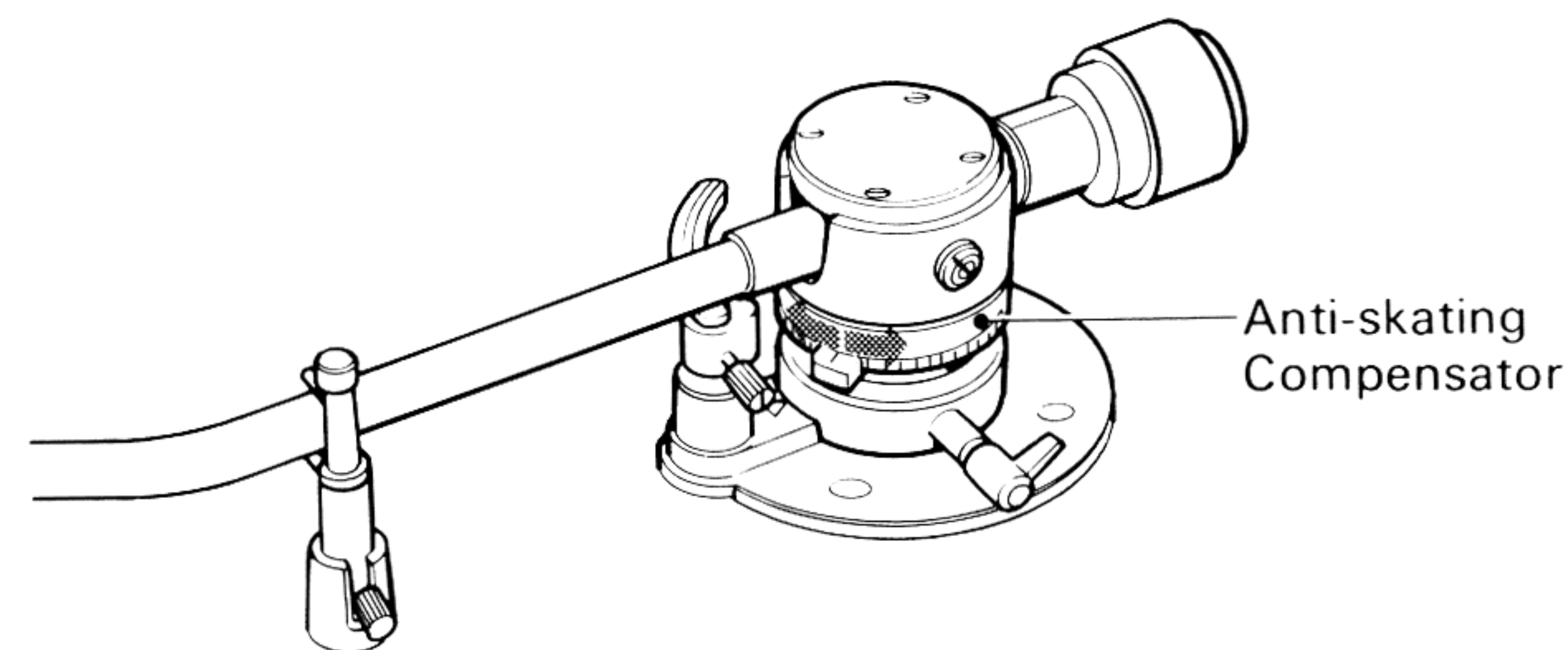

#### Tonearm height adjustment

- ① Place a record on the platter and lower the cartridge onto a record.
- ② Release the Tonearm Height Adj. Knob toward you and move it in the required direction so that the tonearm becomes parallel to the turntable.
- Calibration is in mm.
- ③ When the adjustment is complete, lock the Knob.
- ④ Lift up the Tonearm from the record surface by setting the Cueing Lever to the [ ▼ ] position. Be sure that the distance between the stylus tip and the record is 5 to 10 mm. If not, adjust the height of the Tonearm Platform by loosening its screw as illustrated. Adjust so that the Tonearm Platform do not swerve from a concentric circle.

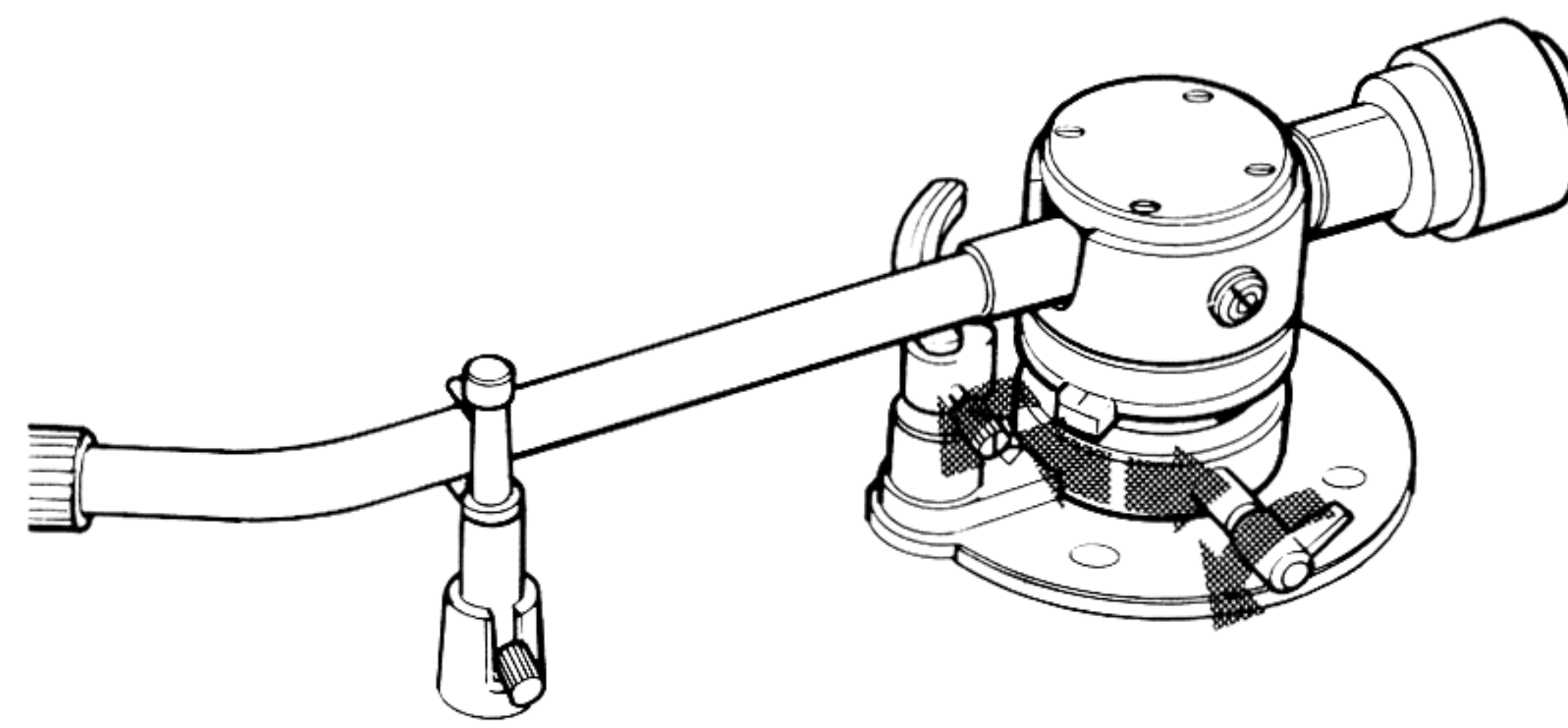

#### Arm Rest height adjustment

When the Tonearm height is changed, the Arm Rest height adjustment is also required.

- ① Be sure that the Tonearm Platform is up.
- ② Pull up the upper portion of the Arm Rest and turn it clockwise. Place the Tonearm on the Arm Rest.
- ③ Loosen the screw so that no clearance is left between the Tonearm and the Arm Rest. Retighten the screw.

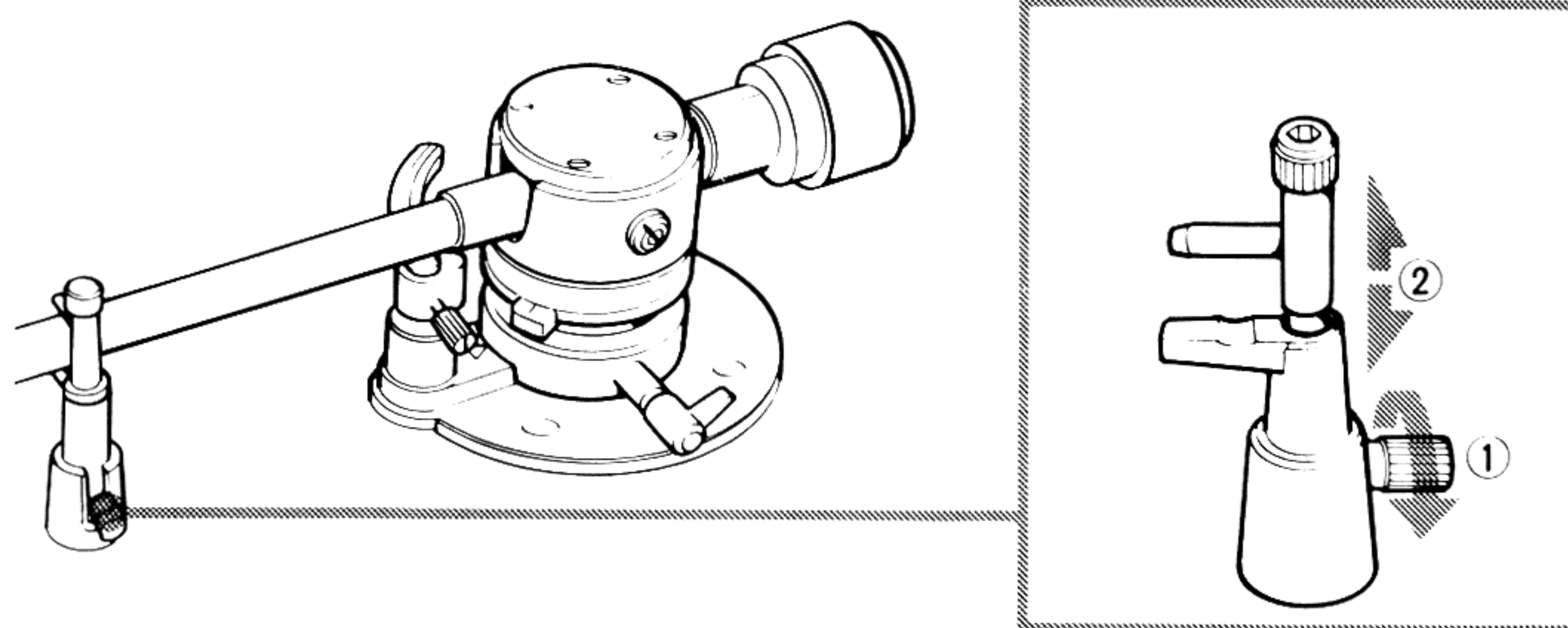

#### \*1 Longitudinal balance adjustment

While playing the record, the weight of the tonearm is supported by the arm pivot and only tracking force is applied to the stylus tip. To accomplish this, the tonearm must first be balanced horizontally, with the tracking force indicator set at "0".

#### \*2 Tracking force

After the longitudinal balance adjustment, apply the recommended tracking force weight so that the stylus tip will trace the music groove accurately.

#### \*3 Overhang

In record playing, because of the pivoted design of the tonearm, the stylus tip can be perfectly tangent to the music groove at only one point of the record. At all other portions of the record, there is a slight deviation of the stylus from tangency. This is called the tracking error, and introduces minute errors in the amplitude and timing of the reproduced signal as compared to the original, and other forms of distortion which may be introduced depending on the cartridge and stylus design.

Tracking error is minimized by the selection of an optimum "off-set" angle and "overhang" distance. Overhang is the distance between the stylus tip and the center spindle. This overhang adjustment is made at the time of installing a particular cartridge, while the off-set angle is fixed by the manufacturer of the tonearm.

#### \*4 Anti-skating compensation

While the record is being played, the frictional force between the record groove and the stylus produces a force that tends to drive the tonearm toward the center of the record. The anti-skating compensation cancels the above mentioned force, and is applied in accordance with the tracking force. Incorrect anti-skating compensation results in sound distortion and uneven wear on both the stylus and the record.

## CONNECTIONS

- Check that the phono cord and power cord are not caught under any foot of the cabinet.
- Leave a little slack in the connecting cord to allow for inadvertent shock or vibration.

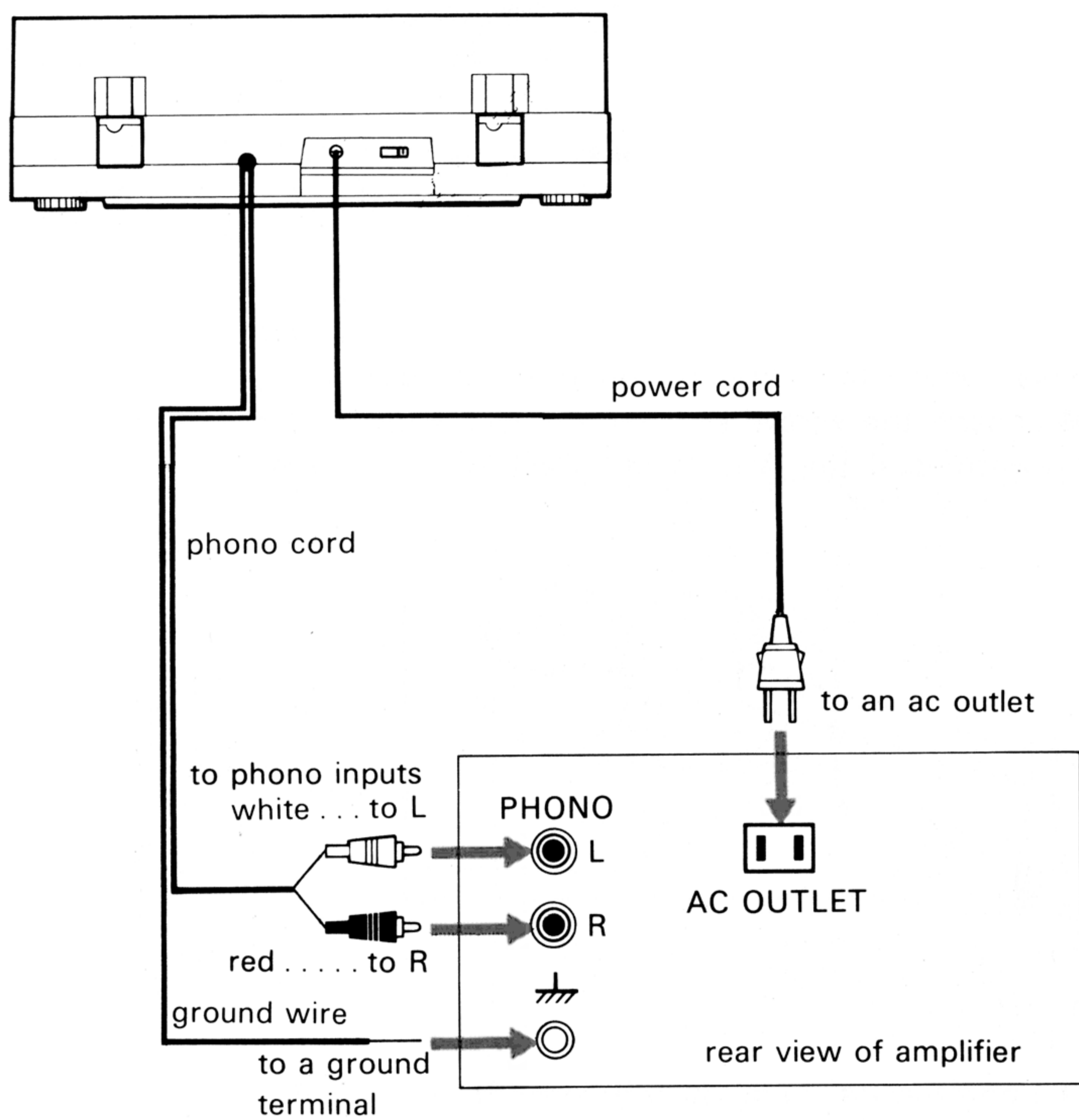

## RECORD PLAYING

Follow in sequence the numbered operations of the diagram.

- 1 Push the POWER Switch. LED Lamp illuminates.
- 2 Place a record on the platter.
  - For 17 cm (7-inch) records, put the supplied 45-rpm adaptor.
- 3 Push the SPEED Button ("33"- or "45"-rpm) according to the record speed.
- 4 Remove the stylus guard while keeping the Tonearm on the Arm Rest.
- 5 Set the Arm Rest as illustrated.
- 6 Set the Cueing Lever to [ ▼ ].
- 7 Push the START/STOP Button. LED Lamp illuminates.
- 8 Bring the Tonearm above the lead-in groove of the record.
- 9 Set the Cueing Lever to [ ▼ ]. The Tonearm will lower on the record and playing will begin.
  - When the Tonearm reaches the end of the record, it will automatically rise and return to the Arm Rest, and the turntable will stop.

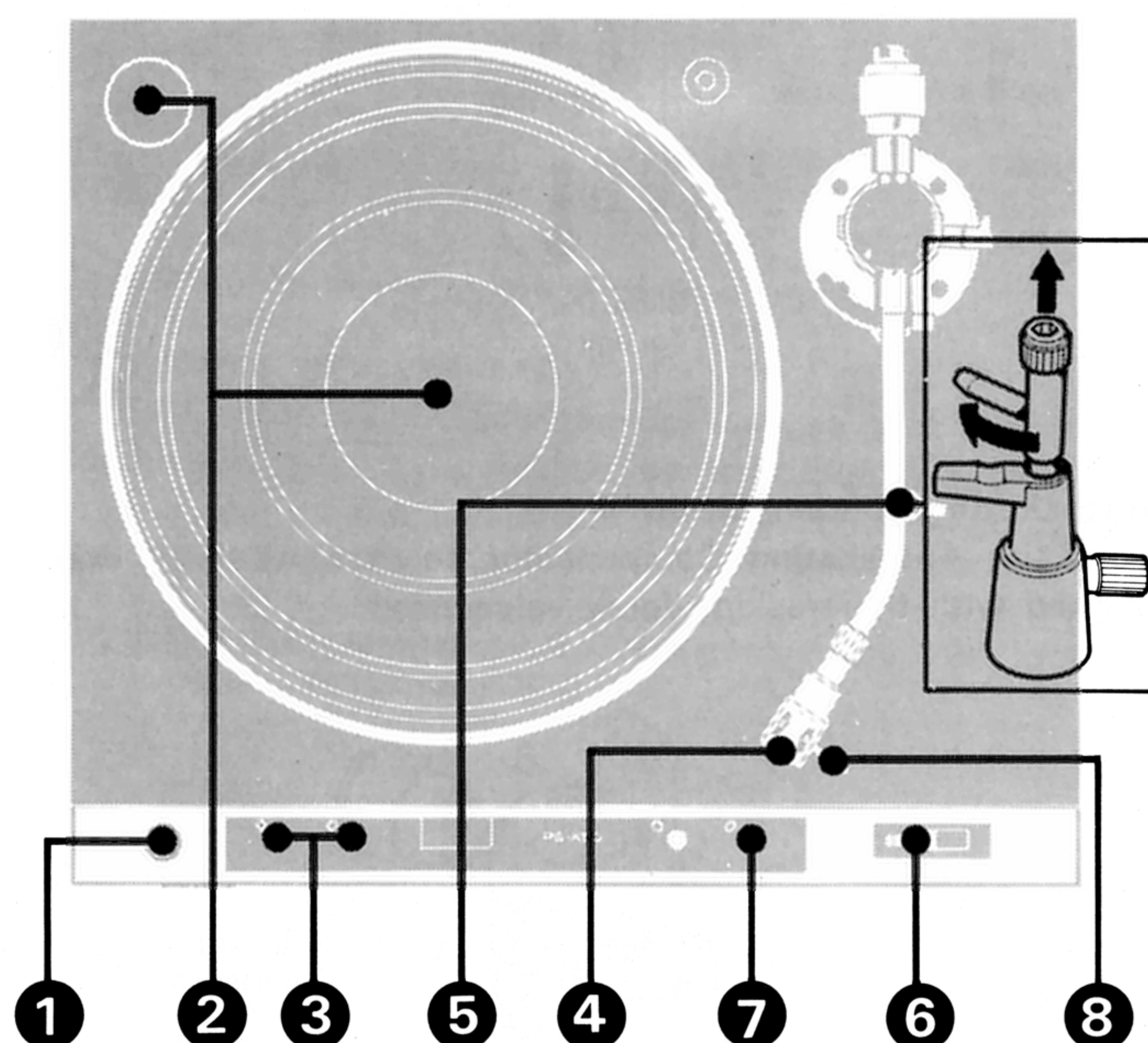



## TIPS ON RECORD HANDLING

### To stop during play

Push the REJECT Button. The Tonearm automatically returns to the Arm Rest.

- To lift up the Tonearm manually, use the Cueing Lever (see "Cueing lever").

### NOTES

- If you bring the Tonearm too near the label of the record while the turntable is rotating, the Tonearm may return to the Arm Rest as a result of having activated the automatic return mechanism.
- Do not push the REJECT button when the Tonearm is locked on the Arm Rest.

### Cueing lever

This lever is used to lower the Tonearm when playing, or to raise the Tonearm manually during play or to change the listening point.

### Stroboscope and neon lamp

The Crystal Lock System assures precise turntable speed. This is verified by viewing the neon lamp stroboscope pattern, which will appear stationary at the correct speed. The upper line is for 45 rpm and the lower for 33 1/3 rpm.

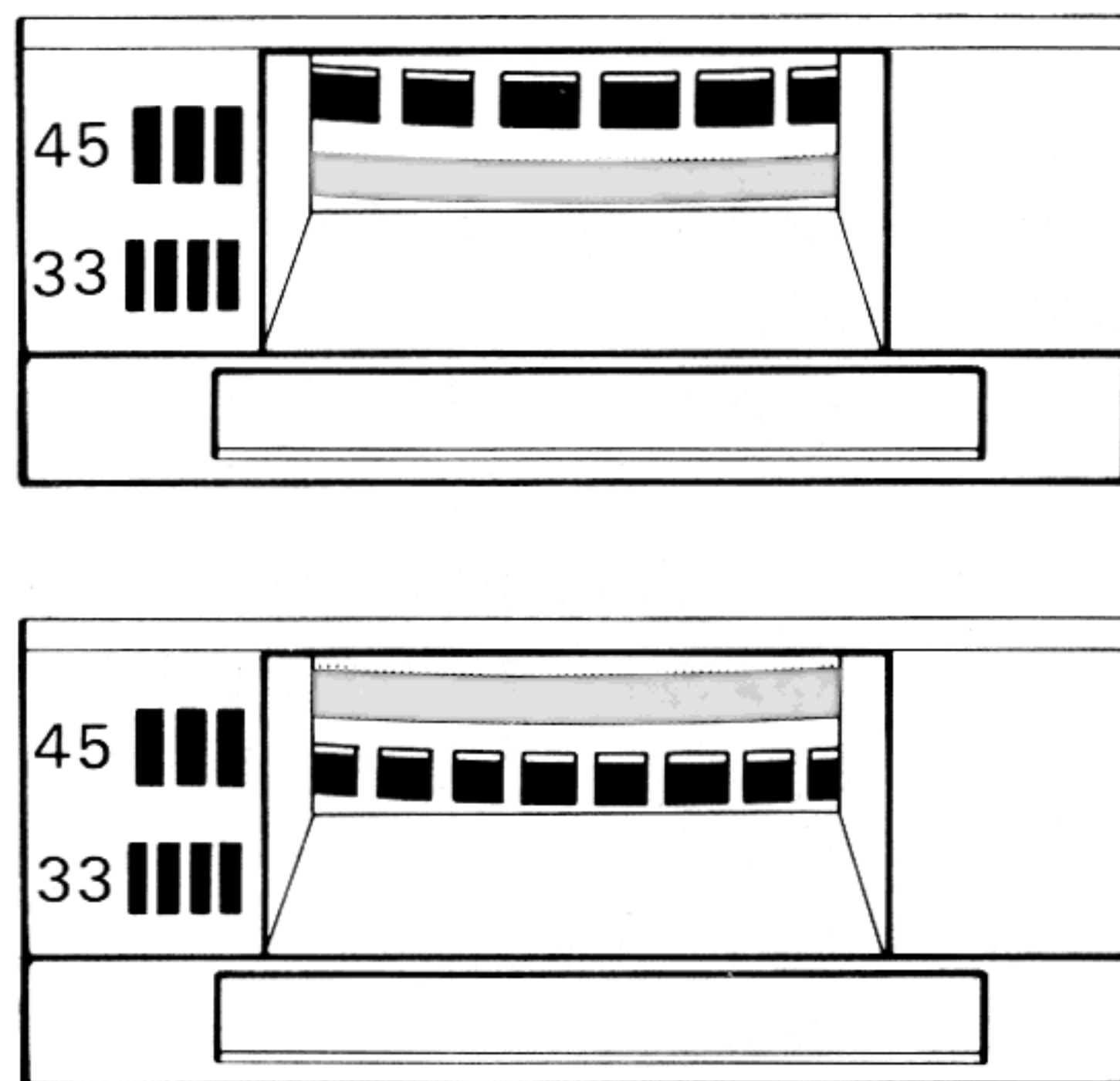

- The neon lamp is energized by a 120 Hz pulse from the built-in crystal oscillator and assures precise speed indication regardless of any line-frequency deviation.

### Before playing

- Clean the stylus, using a soft brush (stylus brush, artist's paint brush, etc). Brush the stylus from back to front. Never attempt to clean the stylus with your finger tip.
- For routine cleaning of records, the use of a barely damp soft cloth (gauze, etc.) or a fluid type cleaner will be effective. If a spray type record cleaner is used, make sure that the cleaner has dried completely before playing the records. Playing the record before the fluid has dried may damage the record. It is a good idea to clean the record again before putting it away.
- Handle a record by its edges and don't touch the music grooves. Finger prints on the record surface may induce an accumulation of dust, resulting in impaired tone.

### When record playing

- It is recommended that you reduce the amplifier volume before you lower the tonearm onto the record.
- While the turntable is energized, don't attempt to stop or reverse the turntable by hand.
- During play, be sure to close the dust cover. Don't place anything on the dust cover.
- While playing, never attempt to move the turntable or touch the tonearm.

### After playing

- Avoid exposing records to any source of heat, such as direct sunlight, a hot-air duct, etc. Store records vertically without applying any pressure or inclining to either side. This will minimize any warpage.
- When not using the turntable, close the dust cover.

### Other precautions

- Don't put anything but records on a turntable.
- Don't place anything but the spare cartridges and 45-rpm adaptor on the turntable deck.

## MAINTENANCE

- Clean the cabinet and dust cover periodically with a soft dry cloth. Do not use solvents such as alcohol, benzine or thinner, since they will damage the finish.
- When the rubber mat becomes dirty, wipe it gently with a soft cloth slightly dampened with water.
- No lubrication is required for this turntable. The motor shaft is factory lubricated for the life of the turntable.

## REPACKING FOR SHIPMENT

The original shipping carton and packing material (which we asked you to save) are the ideal container for use in shipping the unit for repair work, or to another location. To secure the maximum protection, it must be repacked in this material precisely as before. The proper repacking procedure is shown in the illustration.

- Clip the tonearm to the arm rest and bind it there with a tape.
- Fasten the transit screws in their original position by referring to the illustration of "TURNTABLE ASSEMBLY" to secure the inside parts to the cabinet. Turn the screws fully clockwise.

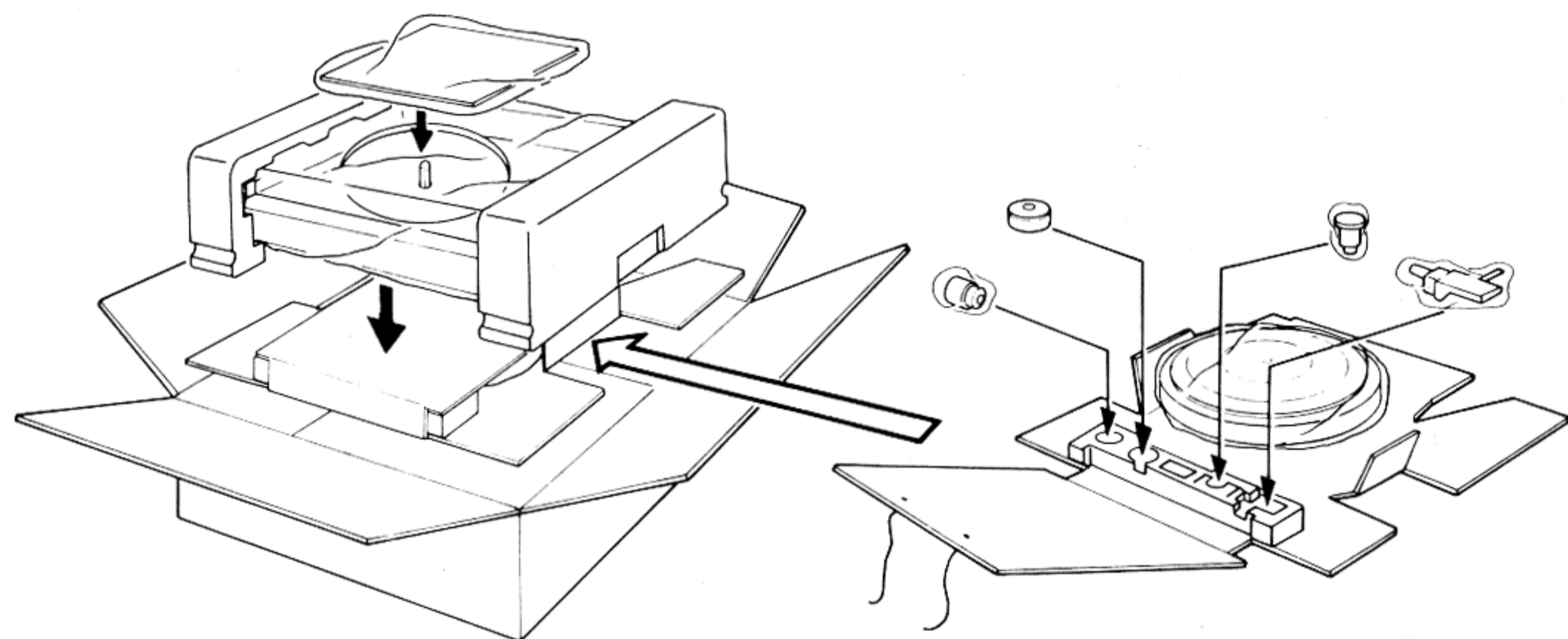

## SPECIFICATIONS

### Turntable

Platter	32 cm (12 5/8 in.), aluminum-alloy diecast
Motor	Linear BSL (brushless and slotless) motor
Drive system	Direct drive, crystal lock control system
Speed	33 1/3 rpm, 45 rpm
Starting characteristics	Comes to nominal speed within a second revolution (33 1/3 rpm)
Wow and flutter	0.025% (WRMS)
Signal-to-noise ratio	75 dB (DIN-B)
Load characteristics	0% at 150 g tracking force return, reject
Automatic system	

### Tonearm

Type	Statically balanced, universal
Pivot-to-stylus length	235 mm (9 1/4 in.)
Overall arm length	330 mm (13 in.)
Overhang	14 mm (9/16 in.)
Tracking error	+2°27' - 1°30'
Tracking force adjustment range	0 - 2.5 g
Shell weight	11 g
Cartridge weight range (including shell weight)	11 - 19.5 g 19 - 27.5 g (with extra weight)

### General

Power requirements	120 V ac, 60 Hz
Power consumption	8 W
Dimensions	Approx. 480 × 165 × 420 mm (w/h/d) (18 15/16 × 6 1/2 × 16 9/16 in.) including projecting parts and controls
Weight	Approx. 11.5 kg (26 lbs 7 oz), net Approx. 13 kg (28 lbs 11 oz), in shipping carton
Supplied accessories	45-rpm adaptor Shell Extra weight

Design and specifications subject to change without notice.

## TROUBLE CHECKS

The following chart will help correct most problems which may occur with the unit. If the problem persists after you have made these checks, consult your Sony Service Station or Sony dealer.

### **Impaired tone quality**

- Turntable not level
- Unit incorrectly placed on or near a speaker
- Dusty stylus
- Worn stylus or defective record (The stylus life is approx. 400 hours of playing time.)
- Incorrect cartridge installation
- Improper tonearm balance
- Improper tracking force
- Improper setting of the Anti-skating Compensator
- Improper turntable speed

### **No audio from one channel**

- Loose attachment of the shell to the tonearm
- Loose connection of phono cord
- Low volume level setting for one channel of the amplifier
- Incorrect connection of the shell lead wires

### **Groove skipping, Tonearm tends to skate out, Tonearm does not advance (record repeats)**

- Turntable not level
- Defective record
- External vibrations
- Improper tracking force
- Improper setting of the Anti-skating Compensator

### **Steady low-pitched sound (hum)**

- Loose ground wire connection to the amplifier
- Loose connection between the shell and the tonearm
- Incorrect connection of the shell lead wires
- Transit screws not removed

### **Loud rumble or low-frequency "howl" which occurs when playing a record at high sound levels (acoustic feedback\*)**

- Put the turntable on a sturdy surface.
- Put the turntable as far away from the speakers as possible.
- If the above does not rectify the problem, try commercially available acoustic insulators designed to be put between the feet and shelf.

\* Acoustic feedback: The vibration of speakers is transmitted through the air or via solid objects (shelves, cabinets, floor, etc.) to the turntable, picked up by the cartridge stylus, amplified, and again reproduced through the speakers.